

SwingMi Home 1W

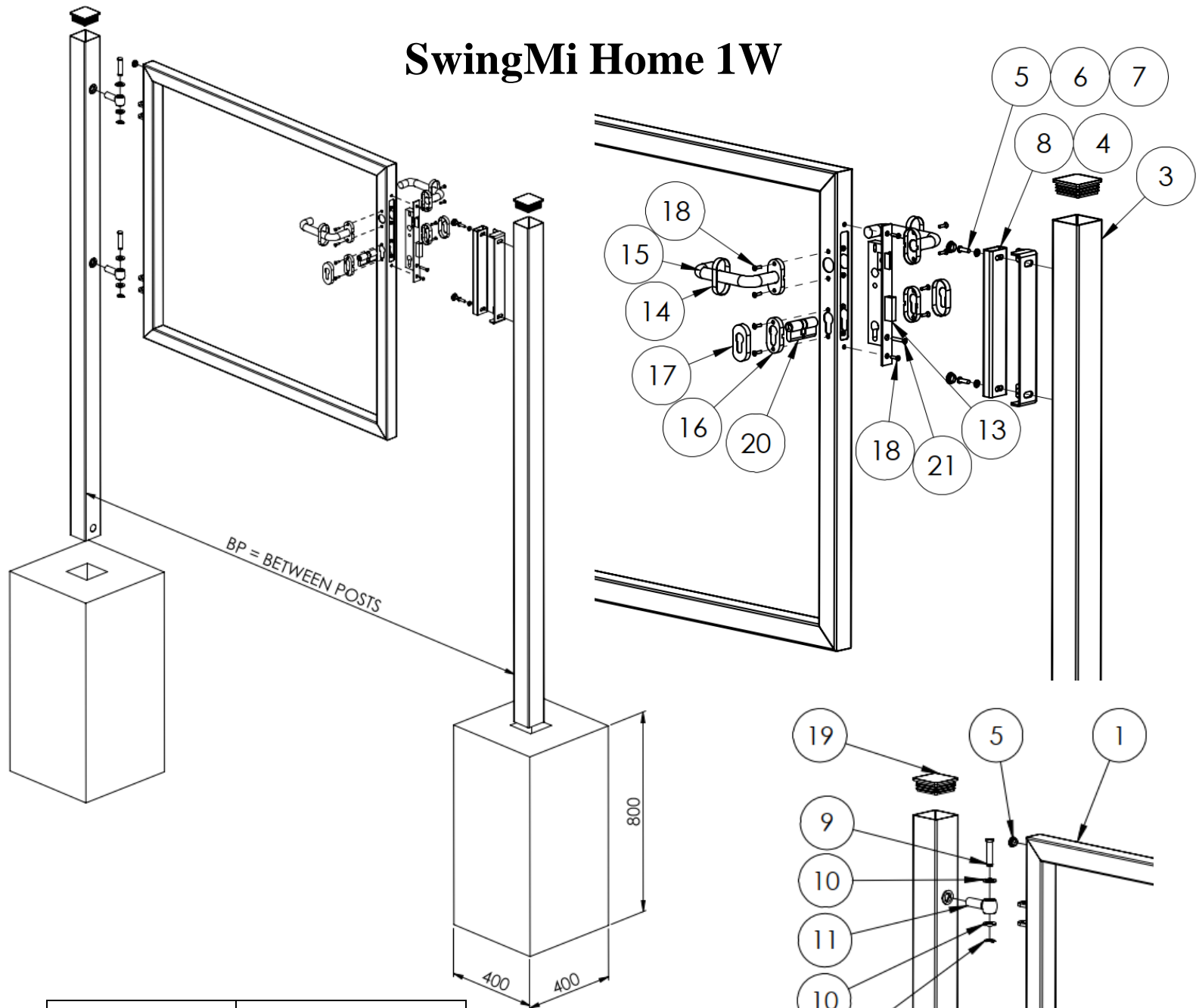

ENGLISH	DEUTSCH
1.Wing	1.Flügel
2.Hinge Post	2.Scharnierpfosten
3.Latch Post	3.Riegelpfosten
4.Slam plate	4.Anschlagblech
5.Plug ϕ 15	5.Kappe ϕ 15
6.Screw M6x20	6.Schraube M6x20
7.Washer M6	7.Scheibe M6
8.Wing Catcher	8.Flügel Fänger
9.Pin	9.Bolzen
10.Washer M12	10.Scheibe M12
11.Hinges	11.Scharnier
12.Seger Ring	12.Seger Ring
13.Lock	13.Schloss
14.Rosette 1	14.Rosette 1
15.Handle	15.Flügelgriff
16.Cover shield	16.Abdeckschild
17.Rosette 2	17.Rosette 2
18.Screw M4x16	18.Schraube M4x16
19.Plastic cap 60x60	19.Kunststoffkappe 60x60
20.Cilinder	20. Profilzylinder
21.Screw M5x30	21.Schraube M5x30

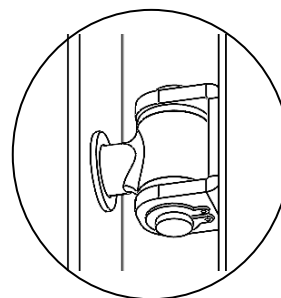

After assembly/ Nach montage

Gate Width [mm]	BP [mm]	Post section [mm]
1000	1040	60x60
1200	1240	60x60
1500	1525	60x60

LOCK ASSEMBLY/ SCHLOSSEINBAU

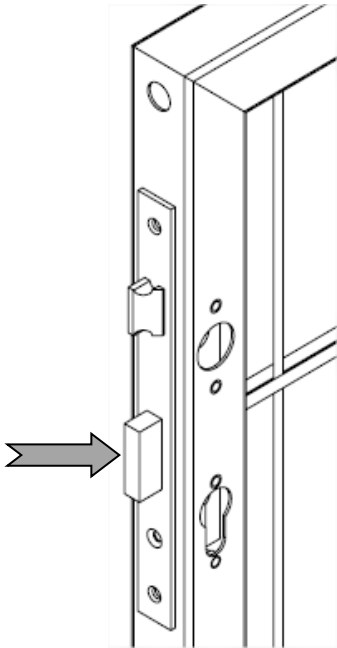

1.Insert lock into the wing.
1.Schloss in den Flügel montieren.

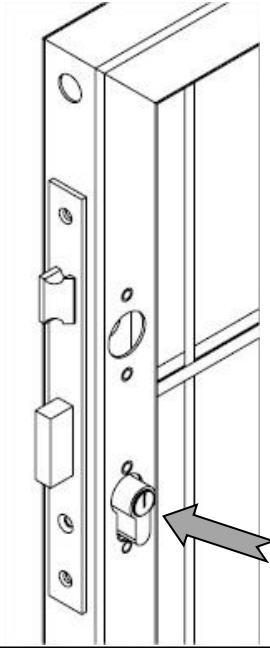

2.Insert cylinder into lock.
2.Profilzylinder in Schloss montieren.

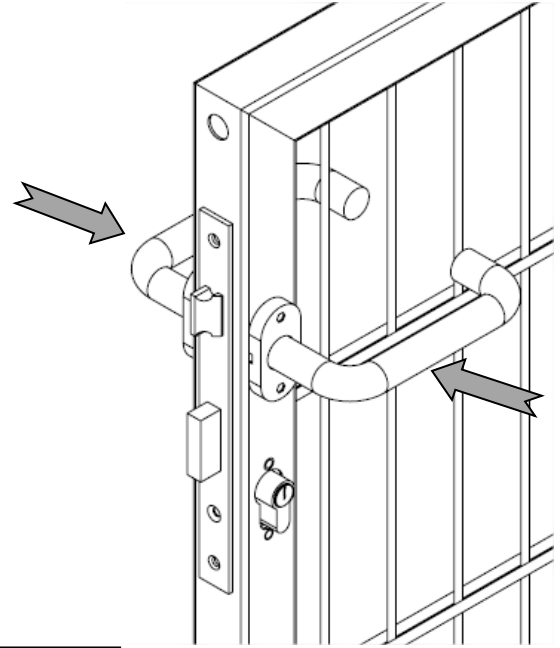

3.Assemble handles together into wing.
3.Flügelgriffe beidseitig in Flügel montieren.

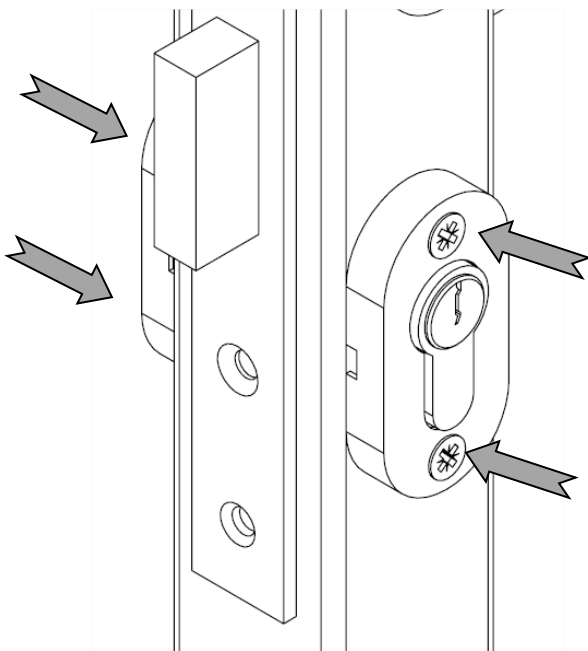

4.Rosettes fix using M4 Screw (don't tighten, cylinder must be symmetrically installed).

4. Rosetten mit M4 Schraube befestigen (nicht fest anziehen, Profilzylinder muß symmetrisch eingebaut sein).

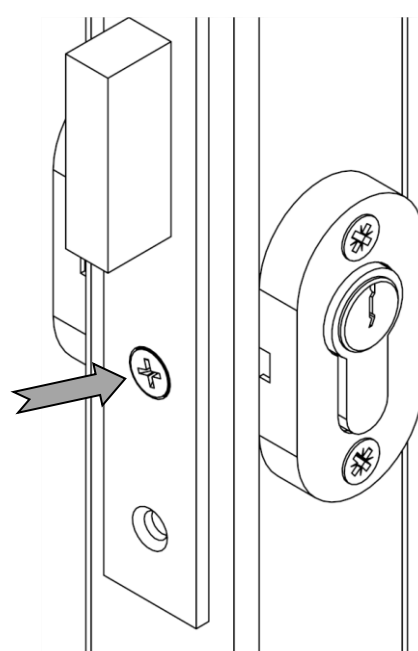

5. Lock cylinder with M5 screw tighten.

5. Profilzylinder mit M5 Schraube festschrauben und anziehen.

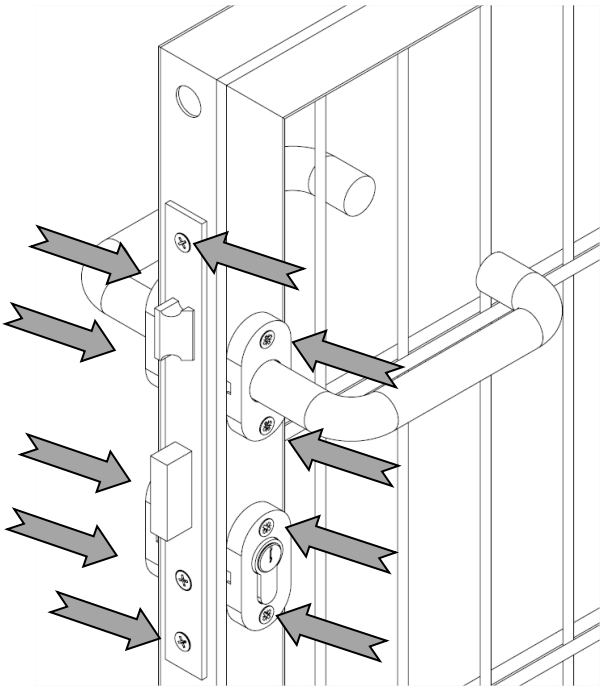

6. When the cylinder is positioned in middle, tighten all screws.
6. Wenn der Profilzylinder in der mitte ist alle Schrauben festziehen.

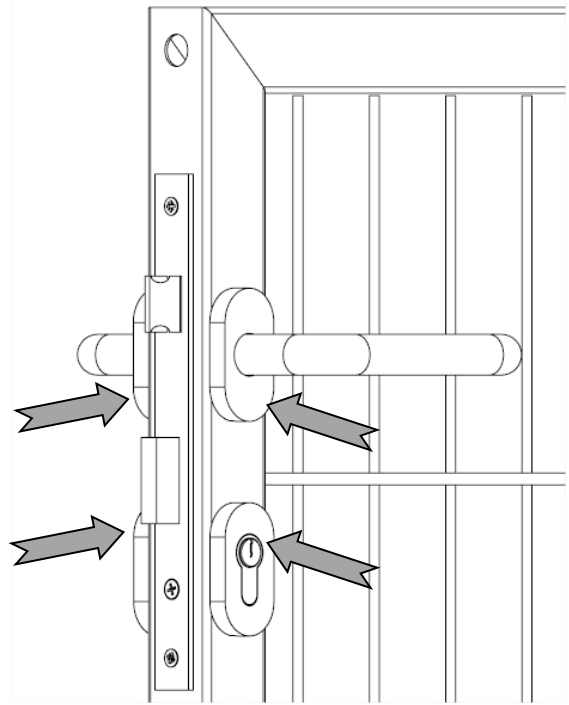

7. Rosetten assembly.
7. Rosetten montieren.

